

## A high efficiency, low loss, low cost option.

As energy costs continue to rise, maximizing the efficiency of electrical distribution systems becomes a top priority. Transformer efficiency is determined by losses (heat). For a transformer to operate most efficiently, it must be designed to operate at the lowest possible heat output. The lower the heat, the lower the losses. Sola/Hevi-Duty's low temperature rise transformers feature a 220 °C insulation system and temperature rise of only 80 °C or 115 °C under full nameplate load. The result is 13-21% lower operating losses than conventional 150 °C rise units. With operating costs substantially reduced, you will save more each year over the transformer's normal life.

Low losses and money savings are not the only benefits of Sola/Hevi-Duty low temperature rise transformers. The 35 °C thermal reserve on 115 °C rise units and 70 °C reserve on 80 °C rise units definitely mean lower operating costs. The extra benefit is being able to operate either of these transformers as a 150 °C rise unit and have an overload capability of 15-30% **without** compromising normal life expectancy (See Figure 1).

Low temperature rise transformers are designed for any critical application requiring extra overload capability, lower than average total losses and/or cooler operating temperatures. All are available with either a 115 °C or 80 °C thermal rise and a fully coordinated class 220 °C insulation system.



## Features

- Shielded – for quality power.
- UL-3R outdoor enclosure with optional weather shield.\*
- Thermal reserve allows for continuous overload operation at 150 °C rise.
- Aluminum windings for greater insulation life.
- Class 220 °C insulation system, 115 °C or 80 °C rise.
- Single and three phase availability.

\* Contact **Technical Services** for weather shield information.

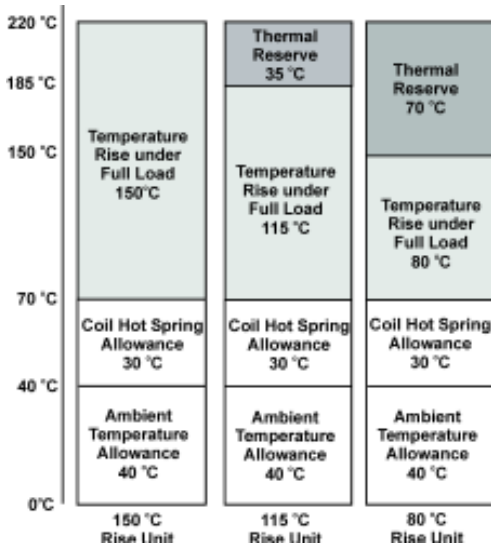
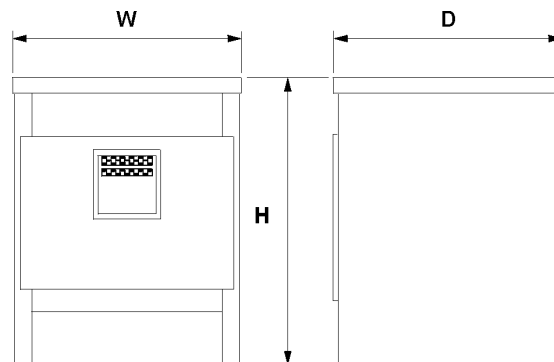

Figure 1



## Tap Information

All Sola/Hevi-Duty low temperature rise transformers are provided with two 2½% FCAN and four 2½% FCBN taps in addition to the nominal rating tap. For actual tap voltage, refer to the appropriate electrical connection diagram.

## Selection Tables: Single Phase



Listed



Certified

### Groups 1 & 3 – 240 x 480 Volt Primary, 120/240 Secondary, 60 Hz

KVA	Catalog Number 80 °C Rise	Catalog Number 115 °C Rise	Height (inch)	Width (inch)	Depth (inch)	Approx. Ship Weight (lbs)	Elec Conn	Primary Amps	Secondary Amps
15	S5HB15S	S5HF15S	28.0	16.0	16.0	250	1	62.5/31.3	125/62.5
25	S5HB25S	S5HF25S	31.0	17.8	18.0	300	1	104/52.1	208/104
37.5	S5HB37S	S5HF37S	31.0	17.8	18.0	385	1	156/78	313/156
50	S5HB50S	S5HF50S	44.0	23.0	21.0	540	1	208/104	416/208
75	S5HB75S	S5HF75S	44.0	23.0	21.0	630	1	313/156	625/313
100	S5HB100S	S5HF100S	46.0	26.0	24.0	900	1	417/208	833/417

### Groups 2 & 4 – 600 Volt Primary, 120/240 Secondary, 60 Hz

KVA	Catalog Number 80 °C Rise	Catalog Number 115 °C Rise	Height (inch)	Width (inch)	Depth (inch)	Approx. Ship Weight (lbs)	Elec Conn	Primary Amps	Secondary Amps
15	S10HBF15S	S10HF15S	28.0	16.0	16.0	250	2	25.0	125/62.5
25	S10HBF25S	S105HF25S	31.0	17.8	18.0	300	2	41.7	208/104
37.5	S105HBF37S	S105HF37S	31.0	17.8	18.0	385	2	62.5	313/156
50	S105HBF50S	S10HF50S	44.0	23.0	21.0	540	2	83.3	416/208
75	S105HBF75S	S10HF75S	44.0	23.0	21.0	630	2	125	625/313
100	S10HBF100S	S10HF100S	46.0	26.0	24.0	900	2	167	833/417

## Selection Tables: Three Phase

### Groups A & D – 480 Δ Primary, 208Y/120 Secondary, 60 Hz

KVA	Catalog Number 80 °C Rise	Catalog Number 115 °C Rise	Height (inch)	Width (inch)	Depth (inch)	Approx. Ship Weight (lbs)	Elec Conn	Primary Amps	Secondary Amps
15	T2HB15S	T2HF15S	28.0	23.0	16.0	300	3	18.1	41.7
30	T2HB30S	T2HF30S	28.0	23.0	18.0	350	3	36.1	83.4
45	T2HB45S	T2HF45S	31.0	26.0	18.0	425	3	54.2	125
75	T2HB75S	T2HF75S	44.0	33.0	21.0	800	3	90.3	208
112.5	T2HB112S	T2HF112S	44.0	33.0	21.0	825	3	135	313
150	T2HB150S	T2HF150S	46.0	36.0	24.0	1350	3	181	417
225	T2HB225S	T2HF225S	46.0	36.0	24.0	1500	3	271	625
300	T2HB300S	T2HF300S	65.0	45.0	35.0	2110	3	361	834

### Selection Tables: Three Phase

Groups B & E – 480 D Primary, 240 Δ Secondary with 120 V Reduced Capacity Center Tap\*, 60 Hz

KVA	Catalog Number 80 °C Rise	Catalog Number 115 °C Rise	Height (inch)	Width (inch)	Depth (inch)	Approx. Ship Weight (lbs)	Elec Conn	Primary Amps	Secondary Amps
15	T5HB15S	T5HF15S	28.0	23.0	16.0	300	4	18.1	36.1
30	T5HB30S	T5HF30S	28.0	23.0	18.0	350	4	36.1	72.3
45	T5HB45S	T5HF45S	31.0	26.0	18.0	425	4	54.2	108
75	T5HB75S	T5HF75S	44.0	33.0	21.0	800	4	90.3	181
112.5	T5HB112S	T5HF112S	44.0	33.0	21.0	825	4	135	271
150	T5HB150S	T5HF150S	46.0	36.0	24.0	1350	4	181	361
225	T5HB225S	T5HF225S	46.0	36.0	24.0	1500	4	271	542
300	T5HB300S	T5HF300S	65.0	45.0	35.0	2110	4	361	723

\* See the Technical Notes section with respect to capacity of center tap.

Group C & F – 600 Δ Primary, 208Y/120 Secondary, 60 Hz

KVA	Catalog Number 80 °C Rise	Catalog Number 115 °C Rise	Height (inch)	Width (inch)	Depth (inch)	Approx. Ship Weight (lbs)	Elec Conn	Primary Amps	Secondary Amps
15	T7HB15S	T7HF15S	28.0	23.0	16.0	300	5	14.5	41.7
30	T7HB30S	T7HF30S	28.0	23.0	18.0	350	5	28.9	83.4
45	T7HB45S	T7HF45S	31.0	26.0	18.0	425	5	43.4	125
75	T7HB75S	T7HF75S	44.0	33.0	21.0	800	5	72.3	208
112.5	T7HB112S	T7HF112S	44.0	33.0	21.0	825	5	108	313
150	T7HB150S	T7HF150S	46.0	36.0	24.0	1350	5	145	417
225	T7HB225S	T7HF225S	46.0	36.0	24.0	1500	5	217	625
300	T7HB300S	T7HF300S	65.0	45.0	35.0	2110	5	289	834

## Electrical Connections

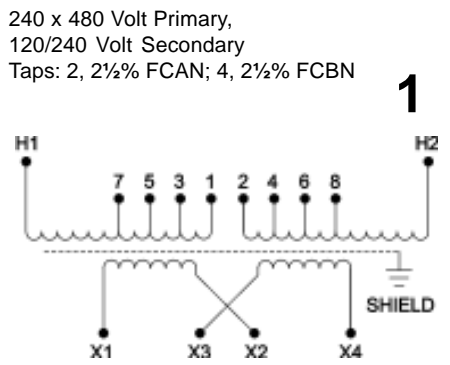

Primary Voltage	Interconnect	Connect Lines To
504	1 to 2	H1 & H2
492	2 to 3	H1 & H2
480	3 to 4	H1 & H2
468	4 to 5	H1 & H2
456	5 to 6	H1 & H2
444	6 to 7	H1 & H2
432	7 to 8	H1 & H2
252	H1 to 2 H2 to 1	H1 & H2
240	H1 to 4 H2 to 3	H1 & H2
228	H1 to 6 H2 to 5	H1 & H2
216	H1 to 8 H2 to 7	H1 & H2
Secondary Voltage	Interconnect	Connect Lines To
240	X2 to X3	X1 & X4
120/240	X2 to X3	X1, X2 & X4
120	X1 to X3 X2 to X4	X1 & X4

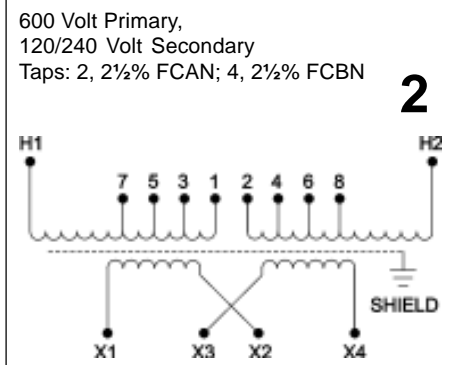

Primary Voltage	Interconnect	Connect Lines To
630	1 to 2	H1 & H2
615	2 to 3	H1 & H2
600	3 to 4	H1 & H2
585	4 to 5	H1 & H2
570	5 to 6	H1 & H2
555	6 to 7	H1 & H2
540	7 to 8	H1 & H2
Secondary Voltage	Interconnect	Connect Lines To
240	X2 to X3	X1 & X4
120/240	X2 to X3	X1, X2 & X4
120	X1 to X3 X2 to X4	X1 & X4

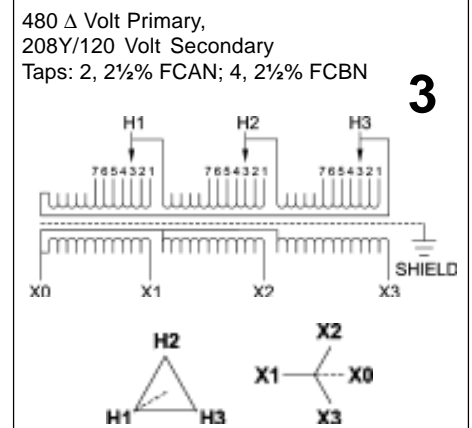

Primary @ Tap	H1-H2-H3 Voltage	Secondary Voltage X1, X2, X3	Secondary Voltage X0-X1, X6-X3
1	504		
2	492		
3	480	240	120
4	468		
5	456		
6	444		
7	432		

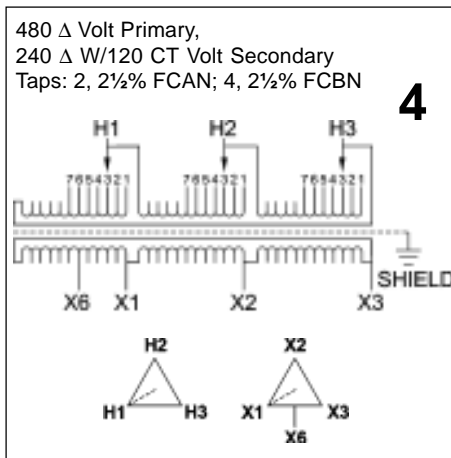

Primary @ Tap	H1-H2-H3 Voltage	Secondary Voltage X1, X2, X3	Secondary Voltage X6-X1, X6-X3
1	504		
2	492		
3	480	240	120
4	468		
5	456		
6	444		
7	432		

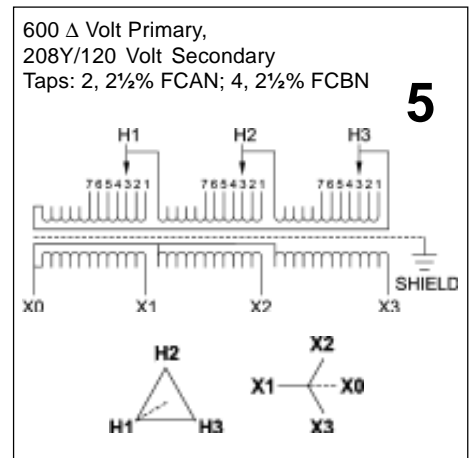

Primary @ Tap	H1-H2-H3 Voltage	Secondary Voltage X1, X2, X3	Secondary Voltage X0-X1, X2, X3
1	630		
2	615		
3	600	208	120
4	585		
5	570		
6	555		
7	540		