

Three Phase Power Conditioners

Features

- Tight regulation of $\pm 5\%$ for protection against sag (-25%) and swell (+15%) conditions.
- Control circuit bypass switch.
- Status indicating lights.
- Shielded, copper wound isolation transformer.
- Surge suppression to ANSI/IEEE and IEC Standards
- High efficiency (97%) microprocessor controlled tap switcher.
- Automatic over and under voltage protection.
- High overload capability.
- UL 544, UL 1012, cUL_{US} Listed.
- Provides optional step down function.

Related Products

- STV100K
- General Purpose Transformers

Applications

- Automatic Packaging Machinery
- Data Rooms
- UPS Bypass Circuits
- Retail Store

Mechanical Specifications

Indicators	Indicating Lamps: 1 red (overtemperature) 3 green (regulated output present)
Connections	Field wired, terminal blocks
Size and Weight	See Selection Table
Safety Agency Approvals	UL 544 and UL 1012 cUL (Canadian Standard C22.2 No 125) Complies with Part 15 Subpart J of FCC rules for a Class A computing device.
Control Circuit By-pass Switch	Switch on front panel can divert input power directly to load, bypassing the voltage regulator.

Environmental Specifications

Audible Noise	Less than 50 dBA at 3 feet
Ambient Temperature	0° to 40°C Operating, 0° to 80°C Storage
Operating Altitude	10,000 feet without derating
Operating Humidity	95% relative (non-condensing)



Electrical Specifications

Power Ratings	10, 15, 22.5, 30, 45, 75, 100, 150 KVA, Three Phase
Nominal Voltages	See Selection Table
Input Voltage Range	-25% to +15% of nominal rated voltage.
Output Voltage Range	Regulated to $\pm 5\%$ of nominal voltage with an input voltage range of -25% to +15%.
Response Time	Responds to any line variation in less than 1.5 cycles maximum, 1 cycle typical, under any condition of line, load or power factor.
Technology	Microprocessor controlled electronic tap switching. 6 taps switched at zero current crossing.
Operating Frequency	57-63 Hz
Load Power Factor	0.6 leading to 0.6 lagging
Insulation Resistance	100 megohms from winding to core measured at 500 VDC
Efficiency	97% typical
Overload Capability	125% of rated load for 1 minute 200% of rated load for 10 seconds 500% of rated load for 1 cycle
EMI	Less than 0.2 gauss at a distance of 3 ft.
Mean Time Between Failure (MTBF)	Exceeds 150,000 hours

Design Style

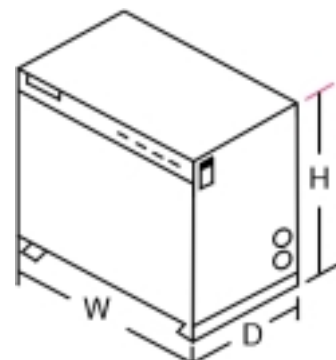

Three Phase Power Conditioners

Protection Specifications

Over / Under Voltage	Output voltage is interrupted should the input voltage exceed the input tolerance of the power conditioner for three consecutive cycles. Output is automatically reapplied once input returns within tolerance window of +10%, -20%.
Short Circuit Protection	Input circuit breaker with shunt trip
Over Temperature Protection	Red lamp indication of overtemperature at approximately 180°C, followed by a shutdown (main circuit breaker shunt trip) at approximately 193°C.

Noise Suppression

Performance Specifications

Common Mode Noise Attenuation	150 dB at 100 kHz
Normal Mode Noise Attenuation	65 dB at 100 kHz
Surge Suppression	Tested to ANSI/IEEE standard C62.41 (IEEE 587 Cat A and B), 1000-4, 1000-5

Selection Table

Output KVA	Catalog Number	VAC Input	Dimensions (HxWxD, inches/cm)	Ship Weight (lbs/kg)
208 VAC Input, 208Y/120 VAC Output, 60 Hz				
10	63T2A310	208	29 x 21 x 19 / 73.5 x 53.5 x 48	265/120
15	63T2A315	208	38 x 24 x 19 / 96.5 x 61 x 48	485/220
22.5	63T2A322	208	38 x 24 x 19 / 96.5 x 61 x 48	530/240
30	63T2A330	208	38 x 24 x 19 / 96.5 x 61 x 48	850/386
45	63T2A345	208	40 x 38 x 28 / 101.5 x 96.5 x 71	940/426
75	63T2A375	208	40 x 38 x 28 / 101.5 x 96.5 x 71	1095/496
100	63T2A410	208	40 x 52 x 28 / 101.5 x 132 x 71	1800/816
150	63T2A415	208	40 x 52 x 28 / 101.5 x 132 x 71	2400/1089
480 VAC Input, 208Y/120 VAC Output, 60 Hz				
10	63T2B310	480	29 x 21 x 19 / 73.5 x 53.5 x 48	265/120
15	63T2B315	480	38 x 24 x 19 / 96.5 x 61 x 48	485/220
22.5	63T2B322	480	38 x 24 x 19 / 96.5 x 61 x 48	530/240
30	63T2B330	480	38 x 24 x 19 / 96.5 x 61 x 48	850/386
45	63T2B345	480	40 x 38 x 28 / 101.5 x 96.5 x 71	940/426
75	63T2B375	480	40 x 38 x 28 / 101.5 x 96.5 x 71	1095/496
100	63T2B410	480	40 x 52 x 28 / 101.5 x 132 x 71	1800/816
150	63T2B415	480	40 x 52 x 28 / 101.5 x 132 x 71	2400/1089
600 VAC & 600Y/346 Input, 208Y/120 VAC Output, 60 Hz				
10	63T2C310	600	29 x 21 x 19 / 73.5 x 53.5 x 48	265/120
15	63T2C315	600	38 x 24 x 19 / 96.5 x 61 x 48	485/220
22.5	63T2C322	600	38 x 24 x 19 / 96.5 x 61 x 48	530/240
30	63T2C330	600	38 x 24 x 19 / 96.5 x 61 x 48	850/386
45	63T2C345	600	40 x 38 x 28 / 101.5 x 96.5 x 71	940/426
75	63T2C375	600Y/346	40 x 38 x 28 / 101.5 x 96.5 x 71	1095/496
100	63T2C410	600Y/346	40 x 52 x 28 / 101.5 x 132 x 71	1800/816
150	63T2C415	600Y/346	40 x 52 x 28 / 101.5 x 132 x 71	2400/1089
480 VAC Input, 480Y/277 VAC Output, 60 Hz				
10	63T2D310	480	29 x 21 x 19 / 73.5 x 53.5 x 48	265/120
15	63T2D315	480	38 x 24 x 19 / 96.5 x 61 x 48	485/220
22.5	63T2D322	480	38 x 24 x 19 / 96.5 x 61 x 48	530/240
30	63T2D330	480	38 x 24 x 19 / 96.5 x 61 x 48	850/386
45	63T2D345	480	40 x 38 x 28 / 101.5 x 96.5 x 71	940/426
75	63T2D375	480	40 x 38 x 28 / 101.5 x 96.5 x 71	1095/496
100	63T2D410	480	40 x 52 x 28 / 101.5 x 132 x 71	1800/816
150	63T2D415	480	40 x 52 x 28 / 101.5 x 132 x 71	2400/1089